



US 20100200008A1

(19) **United States**

(12) **Patent Application Publication**  
**Taieb**

(10) **Pub. No.: US 2010/0200008 A1**

(43) **Pub. Date: Aug. 12, 2010**

(54) **E-CIGARETTE WITH VITAMIN INFUSION**

**Publication Classification**

(76) **Inventor:** Eli Taieb, Sunrise, FL (US)

(51) **Int. Cl.**  
*A24B 1/00* (2006.01)

**Correspondence Address:**  
**JACQUELINE TADROS, P.A.**  
**500 CYPRESS CREEK ROAD WEST, SUITE 350**  
**FORT LAUDERDALE, FL 33309 (US)**

(52) **U.S. Cl.** ..... **131/360**

(57) **ABSTRACT**

A smokeless cigarette that provides for the dispensation of vitamins to the user by way of a vitamin infused cartridge whereby a liquid mixture of vitamins and/or botanicals are injected into a liquid supplying bottle within the nicotine cartridge for inhalation and absorption by the user.

(21) **Appl. No.:** **12/368,185**

(22) **Filed:** **Feb. 9, 2009**

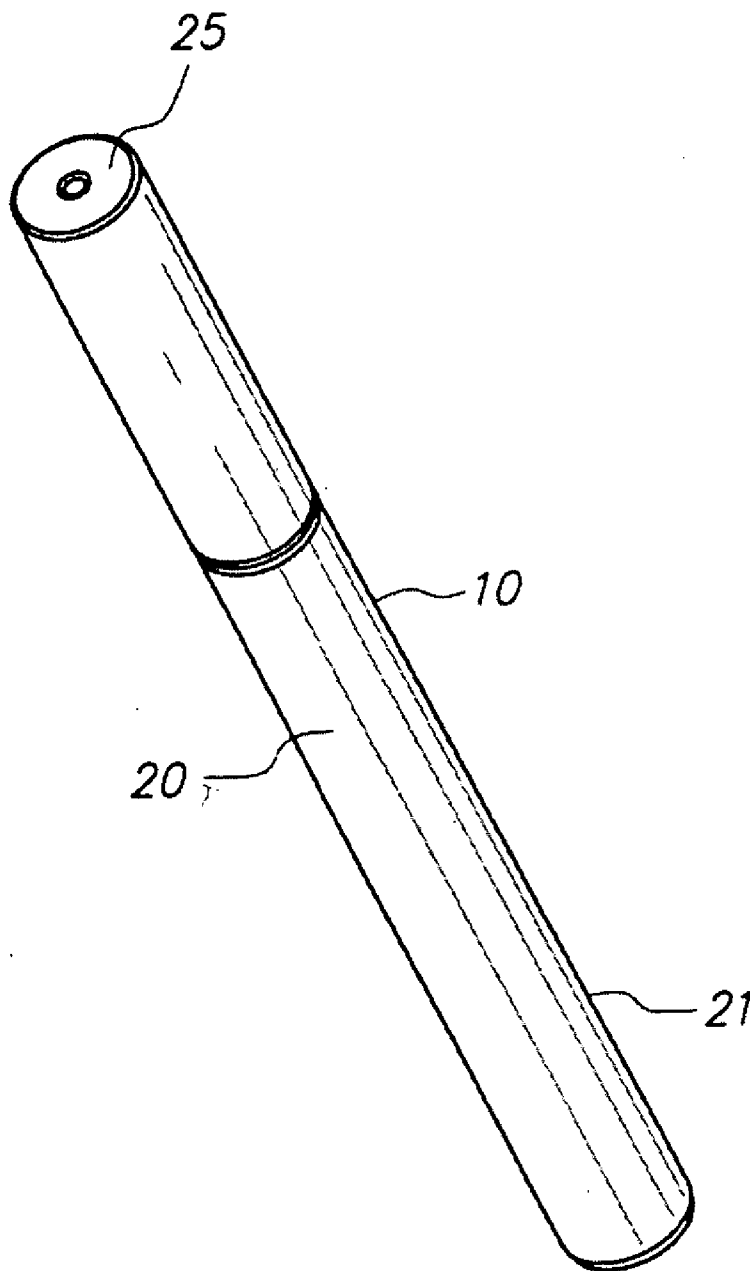

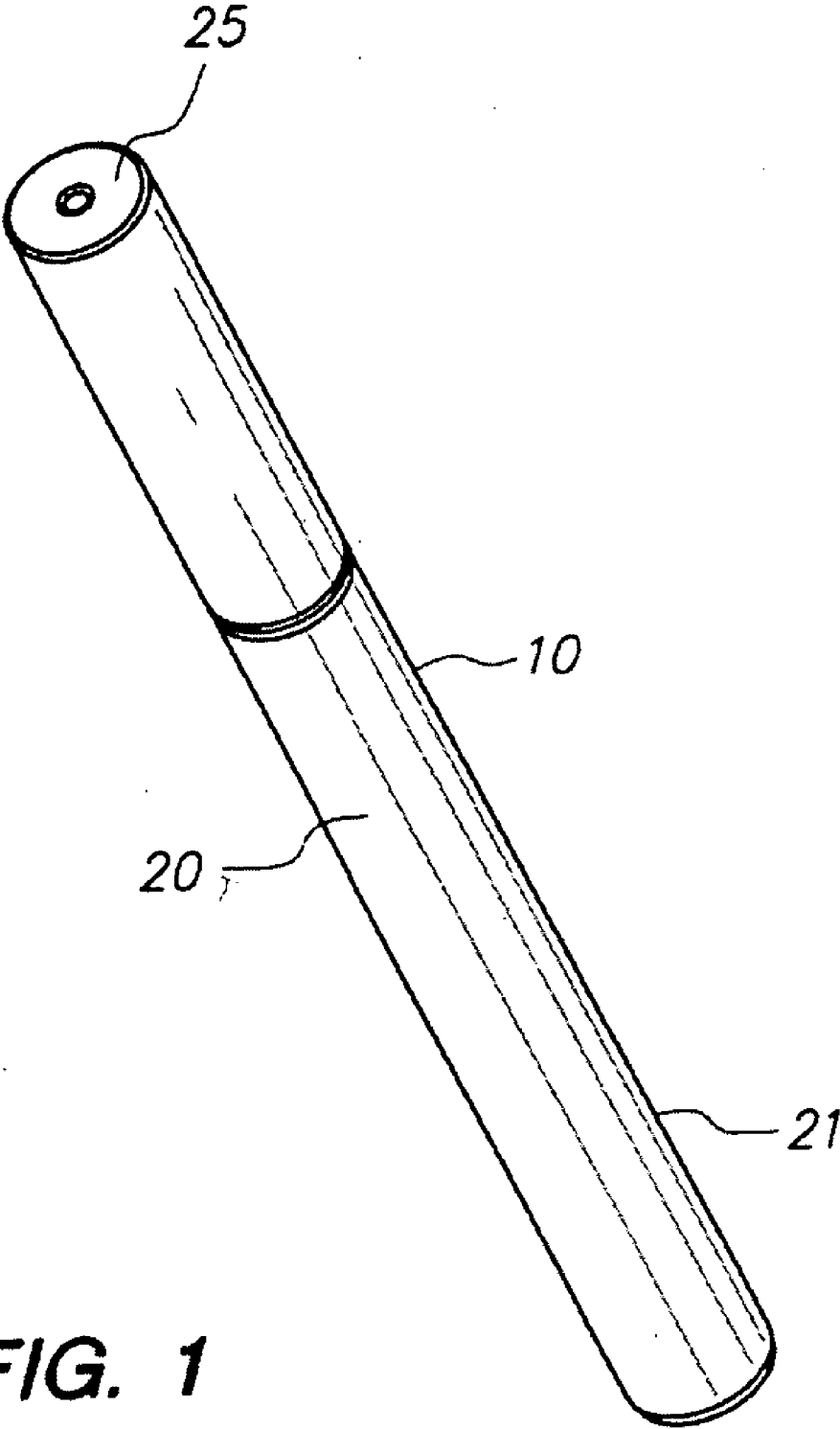

**FIG. 1**

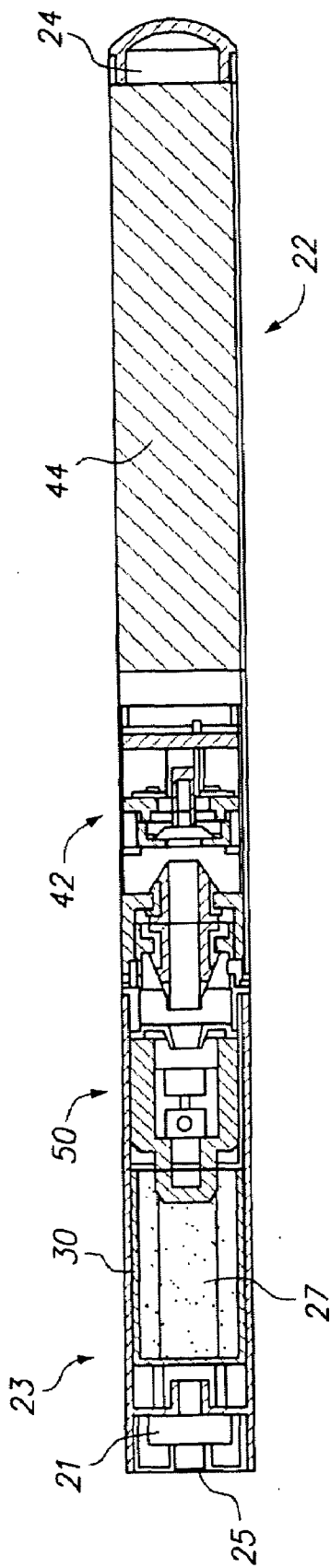
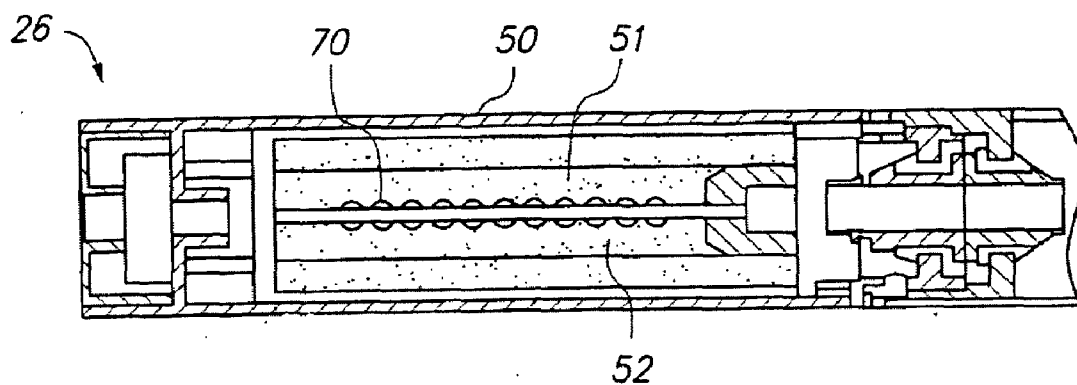

FIG. 2



**FIG. 3**

**E-CIGARETTE WITH VITAMIN INFUSION**

**TECHNICAL FIELD OF THE INVENTION**

**[0001]** The present invention relates to electronic cigarettes. More particularly, an electronic cigarette with a nicotine cartridge that is infused with vitamins in liquid form for absorption by the smoker when using the electronic cigarette.

**BACKGROUND OF THE INVENTION**

**[0002]** In an effort to accommodate the prohibition against smoking indoors in public areas, electronic cigarettes have been provided. Electronic cigarettes allow a smoker to mimic the ritual of smoking while indoors in a public area.

**[0003]** The electronic cigarette is typically a plastic stick that uses a nicotine filter cartridge to simulate the traditional smoking experience. Unlike the traditional smoking experience, however, there is no smoke or tar.

**[0004]** Nearly all electronic cigarettes have the shape of a regular cigarette and provide the user with either a mixture of tobacco aromas, tobacco substitutes, or nicotine/nicotine substitutes as replacements for an all tobacco cigarette.

**[0005]** Several patents on electronic cigarettes have emerged to address the need for smokers to simulate the smoking experience. Many such patents have centered on controlled nicotine delivery. For example, U.S. Pat. No. 4,393,884 enables a user to inhale pressurized nicotine or tobacco-like formulations on demand. The substance and the aerosol propellant such as nitrogen may be placed in the same or separate compartments, depending on the application.

**[0006]** Other patents on smokeless cigarettes add certain compounds to achieve less irritation and antioxidant benefits. U.S. Pat. No. 6,584,980 discusses a substantially pure stabilized compound having Vitamin E activity that is added to smokable or smokeless tobacco or non-tobacco products. For cigarette applications, the Vitamin E compounds can be inserted into a cigarette filter, holder and/or paper, either in powdered form or in microencapsulated form.

**[0007]** The nicotine desire is addressed in U.S. Pat. No. 5,293,883 through the use of an array of small nicotine-containing ampules located within the mouth filter of the smokeless device. The simple device outlined under U.S. Pat. No. 5,284,163 also offers a smoke-free cigarette substitute that includes a tubular sleeve having a nicotine-containing carrier. However, nicotine is drawn into the oral cavity of the user through chewing.

**[0008]** Despite these improvements in electronic cigarettes, cigarettes and smoking continue to be associated with health risks and negative health consequences, such as an increase in heart disease. Smoking and exposure to second-hand smoke both significantly hasten hardening of the arteries, and the damage may be permanent, says a study at Wake Forest University. (“Smoking linked to hardening of the arteries,” AP, The Daily Progress, Charlottesville, Va., Jan. 14, 1998). Smoking damages the arteries to the heart and brain, thereby increasing the risk of heart attack and stroke. (British Medical Journal 1996, in Health Gazette newsletter, February 1997). Smokers are more than 5 times as likely as nonsmokers to develop abdominal aortic aneurysms. (Reuters March 2004).

**[0009]** Carbon monoxide is a byproduct of tobacco smoke that has been found to boost cholesterol, levels of white blood cells and other risk factors for heart disease. The gas can also

impair the blood’s ability to transport oxygen throughout the body, which may raise the risk of heart attack.

**[0010]** Thus, it is desirable to have a product that can accommodate an individual’s desire to mimic the practice of smoking a cigarette which simultaneously complies with the ban on indoor smoking in public areas and addresses the negative health consequences associated with nicotine and smoking.

**SUMMARY OF THE INVENTION**

**[0011]** The objects, features and advantages of the present invention are to provide an electronic cigarette which complies with the ban on indoor cigar and cigarette smoking and avoids the negative consequences of nicotine while providing the user with additional health benefits that can result from the infusion and absorption of vitamins by a user.

**[0012]** The present invention relates to an electronic cigarette that provides for the dispensation of vitamins to the user by way of a vitamin infused cartridge. Vitamins such as for example, Vitamin A, C, D, E and/or botanicals such as antioxidant acai, green tea and grape seed are inserted within the cartridge in liquid form.

**[0013]** The electronic cigarette of the present invention includes a power source, a nicotine infused cartridge, an ultrasonic atomization chamber and a microchip. The anterior portion of the electronic cigarette includes an LED light that is activated when the user initiates the act of smoking and “puffs on” the electronic cigarette as one would with a traditional tobacco cigarette. The atomization chamber generates vapor when heated. The vapor simulates the smoke that is released in traditional smoking. Thus, the electronic cigarette of the present invention replicates the desirable elements of traditional cigarette smoking, such as, the lit cigarette tip, vapor and nicotine of traditional smoking while avoiding the unpleasant effect of second hand smoke and also imparting the beneficial health benefits of vitamin absorption.

**[0014]** In a preferred embodiment a liquid mixture of vitamins or botanicals is injected into a nicotine cartridge. The liquid mixture is absorbed on the cigarette fillers such as wool yarn and cotton rolls, and absorption of the mixture by the user is achieved via inhalation of the mixture.

**[0015]** There has thus been outlined, rather broadly, the more important features of the invention in order that the detailed description thereof may be better understood and in order that the present contribution to the art may be better appreciated.

**[0016]** These as well as additional advantages of the present invention will become apparent of the following detailed description of the present invention when read in light of the several figures.

**BRIEF DESCRIPTION OF THE DRAWINGS**

**[0017]** FIG. 1 is a perspective view of the electronic cigarette.

**[0018]** FIG. 2 is a sectional plan view of an embodiment of the electronic cigarette according to the present invention.

**[0019]** FIG. 3 is a sectional plan view of an alternative embodiment of the electronic cigarette according to the present invention.

**DETAILED DESCRIPTION OF THE INVENTION**

**[0020]** The present invention is described with references to the enclosed Figures wherein the same numbers are utilized where applicable.

[0021] Referring now to FIG. 2, the electronic cigarette 10 of the present invention includes a main body 20, a cartridge 30, and a power source 40.

[0022] The main body 20 includes a housing 21 which encloses the electronic cigarette 10. The outer appearance of the housing 21 resembles that of a traditional cigarette. The housing 21 is generally elongated and cylindrical and is preferably composed of a hard plastic material. The housing further includes an anterior end 22 and a distal end 23. The anterior end 22 of the housing 21 is proximate to a user's mouth. The distal end 23 of the housing 21 is furthest from the user's mouth and includes an LED indicator light 24 that simulates the tip of a traditionally lit cigarette when activated.

[0023] The cartridge 30 includes a absorbent sponge 27, atomization means 50 and a liquid supplying bottle 60. The liquid supplying bottle 60 contains a solution of nicotine and vitamins in contact with the atomization means 50. The solution may also further include water and tobacco flavoring.

[0024] The anterior end 22 of the housing includes a mouthpiece 25 and filter 26. When a smoker initiates the act of smoking, the mouthpiece 24 is under negative pressure and the air pressure thus generated, releases an actuating signal to an IC switch 42 to activate the power source 40. The power source 40 further includes a smart chip (not shown), control panel (not shown) and a lithium ion rechargeable battery 44.

[0025] The activated power source 40 transfers heat to the liquid in the liquid supplying bottle 60. Vapor is generated when the heated liquid makes contact with the atomization means 50.

[0026] In an alternative embodiment, separation means 70 divide the atomization means 50 in two upper and lower sub chambers 51, 52 for generating additional vapor in order to further replicate the traditional smoking experience.

[0027] The IC switch 42 is programmed to release a deactivating signal to the power source 40 to disengage the battery 44 when a smoker inhales too much, thereby limiting the amount of nicotine that the smoker can inhale at any given time. When the nicotine level reaches an acceptable level, the LED indicator light 24 notifies the smoker to start smoking again.

[0028] These as well as additional advantages of the present invention will become readily apparent to one of ordinary skill in the art without deviating from the spirit and scope thereof. Accordingly, while there has been shown and described the preferred embodiment of the instant invention, it is to be appreciated that the invention maybe embodied otherwise than is herein specifically shown and described without departing from the underlying ideas or principles of this invention as set forth in the Claims appended herewith.

I claim:

- 1. An electronic cigarette comprising:
  - a main elongated cylindrical body for enclosing said electronic cigarette, said body having an anterior and distal end;
  - a cartridge, having atomization means, and a liquid supplying bottle wherein liquid in said liquid supplying bottle is in contact with said atomization means;

- a power source having a smart chip, control panel and a lithium ion rechargeable battery for transferring heat to said liquid in said liquid supplying bottle;
  - an IC switch for releasing a signal to activate and deactivate said power source; and
  - an LED indicator light positioned at said distal end for simulating the tip of a traditionally lit cigarette when said power source is activated.
- 2. An electronic cigarette according to claim 1, wherein the body is comprised of a hard plastic material.
  - 3. An electronic cigarette according to claim 1, wherein said atomization means include an upper and lower sub chamber.
  - 4. An electronic cigarette according to claim 1, wherein said anterior end includes a mouthpiece and filter.
  - 5. An electronic cigarette according to claim 1, wherein said liquid supplying bottle contains a solution of nicotine and vitamins.
  - 6. An electronic cigarette according to claim 1, wherein said liquid supplying bottle contains a solution of nicotine and botanicals.

7. A method of infusing an electronic cigarette with vitamins comprising the steps of:

- (a) providing an electronic cigarette having a main elongated cylindrical body for enclosing said electronic cigarette and having an anterior and distal end; a cartridge, having atomization means and a liquid supplying bottle in contact with said atomization means; a power source having a smart chip, control panel and a lithium ion rechargeable battery for transferring heat to said liquid in said liquid supplying bottle; an IC switch for releasing a signal to activate and deactivate said power source; and an LED indicator light positioned at said distal end for simulating the tip of a traditionally lit cigarette when said power source is activated; and
- (b) injecting a solution of liquid vitamins into said liquid supplying bottle.

8. A method of infusing an electronic cigarette with vitamins comprising the steps of:

- (a) providing an electronic cigarette having a main elongated cylindrical body for enclosing said electronic cigarette and having an anterior and distal end; a cartridge, having atomization means and a liquid supplying bottle in contact with said atomization means; a power source having a smart chip, control panel and a lithium ion rechargeable battery for transferring heat to said liquid in said liquid supplying bottle; an IC switch for releasing a signal to activate and deactivate said power source; and an LED indicator light positioned at said distal end for simulating the tip of a traditionally lit cigarette when said power source is activated; and
- (b) injecting a solution of liquid botanicals into said liquid supplying bottle.

\* \* \* \* \*